



UNIVERSITY OF CAMBRIDGE INTERNATIONAL EXAMINATIONS
General Certificate of Education Ordinary Level

CANDIDATE
NAME

CENTRE
NUMBER

--	--	--	--	--

CANDIDATE
NUMBER

--	--	--	--



CHEMISTRY

5070/41

Paper 4 Alternative to Practical

October/November 2011

1 hour

Candidates answer on the Question Paper.

No Additional Materials are required.

READ THESE INSTRUCTIONS FIRST

Write your Centre number, candidate number and name on all the work you hand in.

Write in dark blue or black pen.

You may use a soft pencil for any diagrams, graphs or rough working.

Do not use staples, paper clips, highlighters, glue or correction fluid.

DO NOT WRITE IN ANY BARCODES.

Answer **all** questions.

Write your answers in the spaces provided in the Question Paper.

The number of marks is given in brackets [] at the end of each question or part question.

At the end of the examination, fasten all your work securely together.

For Examiner's Use

--

This document consists of **15** printed pages and **1** blank page.



- 1 What is the volume of liquid in the measuring cylinder?

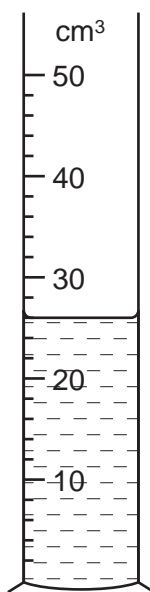

..... cm³ [1]

[Total: 1]

- 2 A student does some tests on hydrochloric acid to investigate its properties.

- (a) A few drops of litmus solution are added to hydrochloric acid. An excess of aqueous sodium hydroxide is added.
What colour change is seen?

The colour changes from to [1]

- (b) A small piece of magnesium is added to hydrochloric acid. A gas is produced.
Name and give a test for this gas.

name

test

observation [2]

- (c) Some powdered calcium carbonate is added to hydrochloric acid.

- (i) What does the student observe?

..... [1]

- (ii) Name and give a test for the gas which is evolved.

name

test

observation [2]

- 3 A student does an experiment to find the formula of magnesium oxide.
A 10 cm length of magnesium is loosely coiled and placed in a weighed crucible.

The crucible is heated for several minutes during which the crucible lid is raised from time to time. The magnesium changes to magnesium oxide.

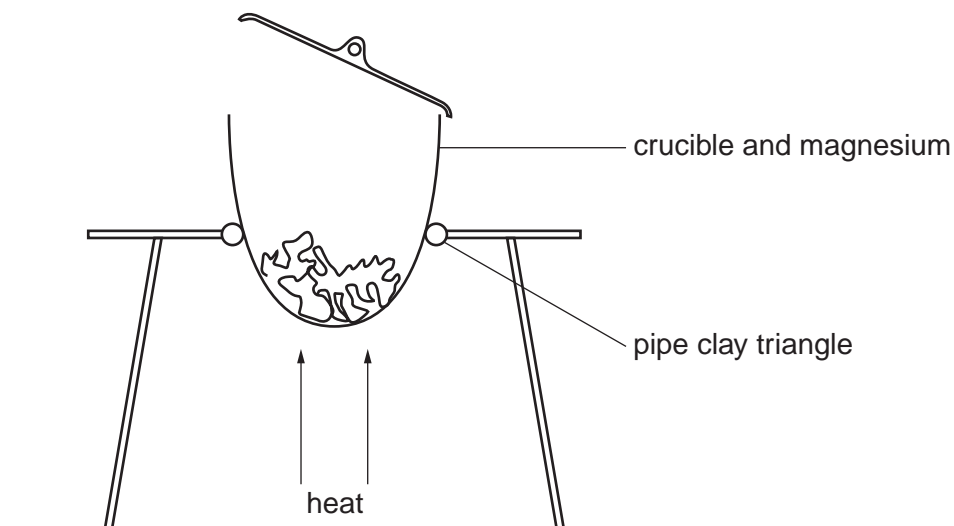

- (a) mass of crucible + magnesium = 14.33 g
mass of crucible = 13.85 g

Calculate the mass of magnesium.

..... g [1]

- (b) Describe the appearance of

(i) magnesium,

.....

(ii) magnesium oxide.

..... [2]

- (c) After cooling, the crucible is weighed.
It is reheated, cooled and reweighed.
Why is this done?

..... [1]

(d) Final mass of crucible + magnesium oxide = 14.65 g

Calculate

(i) the mass of magnesium oxide,

..... g

(ii) the mass of oxygen which reacts with the magnesium.

..... g [2]

(e) Using your answers to (a) and (d)(ii), calculate the formula of magnesium oxide.
[A_r : O, 16; Mg, 24]

..... [2]

(f) (i) Give an equation for a reaction in which magnesium oxide reacts with an acid.

..... [1]

(ii) By referring to your equation, state whether magnesium oxide can be classed as an acidic, basic or amphoteric oxide.

..... [1]

[Total: 10]

In questions 4 to 8 inclusive, place a tick (✓) in the box against the correct answer.

- 4 Ammonia cannot be collected by displacement of water and is, in fact, collected by the method shown in the diagram.

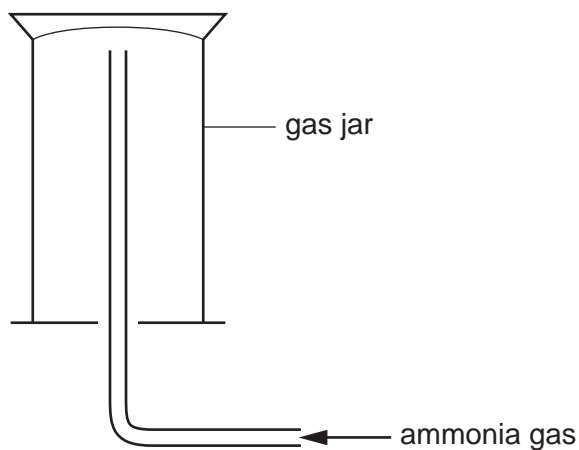

What deductions can you make about the properties of ammonia?

	density	solubility in water	
(a)	more dense than air	soluble	<input type="checkbox"/>
(b)	less dense than air	insoluble	<input type="checkbox"/>
(c)	less dense than air	soluble	<input type="checkbox"/>
(d)	more dense than air	insoluble	<input type="checkbox"/>

[1]

5 In which of the following would the bulb **not** light?

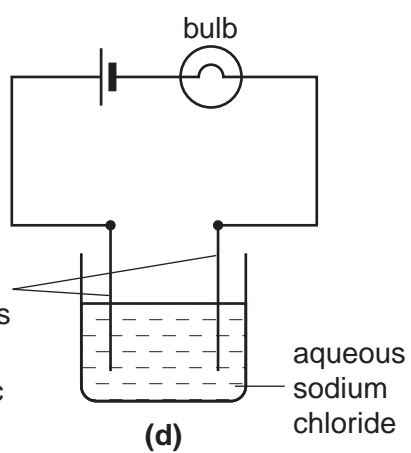
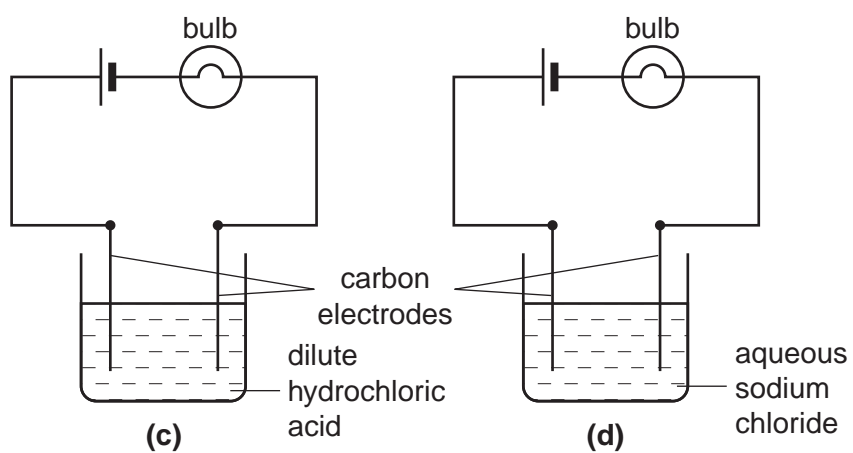
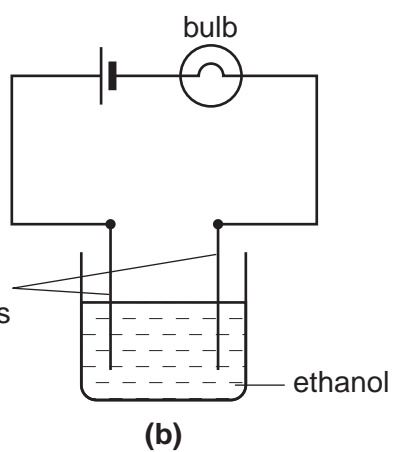
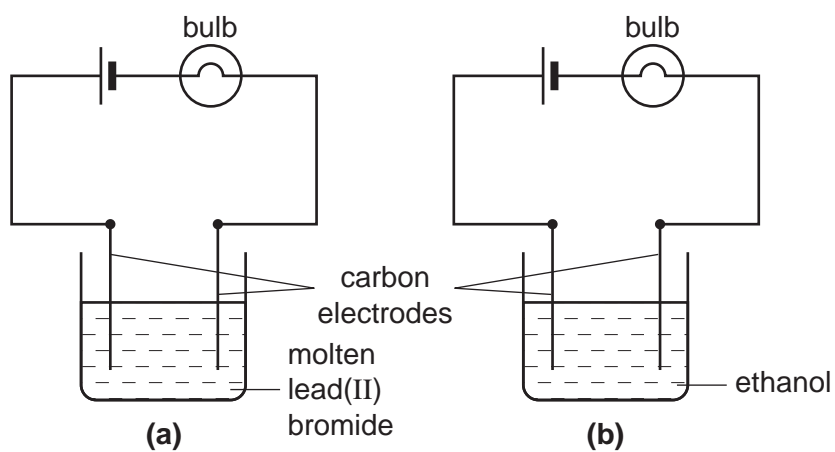

- (a)
- (b)
- (c)
- (d)

[1]

6

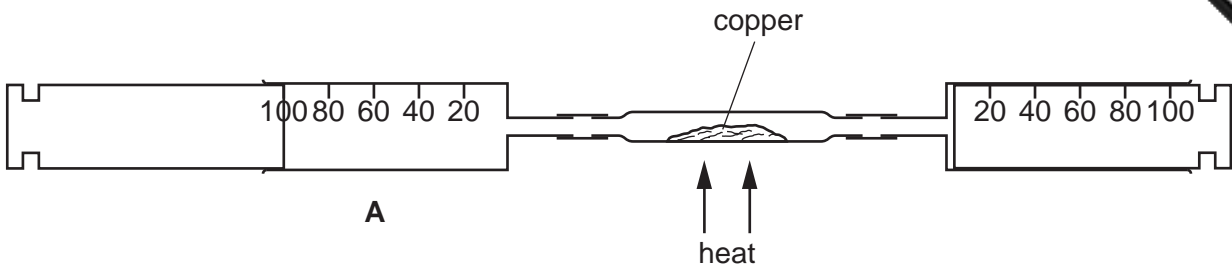

Syringe **A** contains 100 cm^3 of air. The air is forced backwards and forwards over the heated copper until the volume of gas forced back into the syringe **A** is constant.

The gas is cooled to room temperature.

What is the approximate volume of gas in **A** after the experiment is finished?

- (a) 20 cm^3
- (b) 40 cm^3
- (c) 60 cm^3
- (d) 80 cm^3
- (e) 100 cm^3

[1]

7 A student carries out a single experiment to determine the speed of reaction between calcium carbonate and an excess of hydrochloric acid.

Which of the following does **not** change during the course of the reaction?

- (a) concentration of the hydrochloric acid solution
- (b) mass of calcium carbonate
- (c) volume of carbon dioxide evolved
- (d) volume of the hydrochloric acid solution

[1]

- 8 A student does experiments to find how the solubility of potassium nitrate and ammonium sulfate varies with temperature. The results are shown on the graph below.

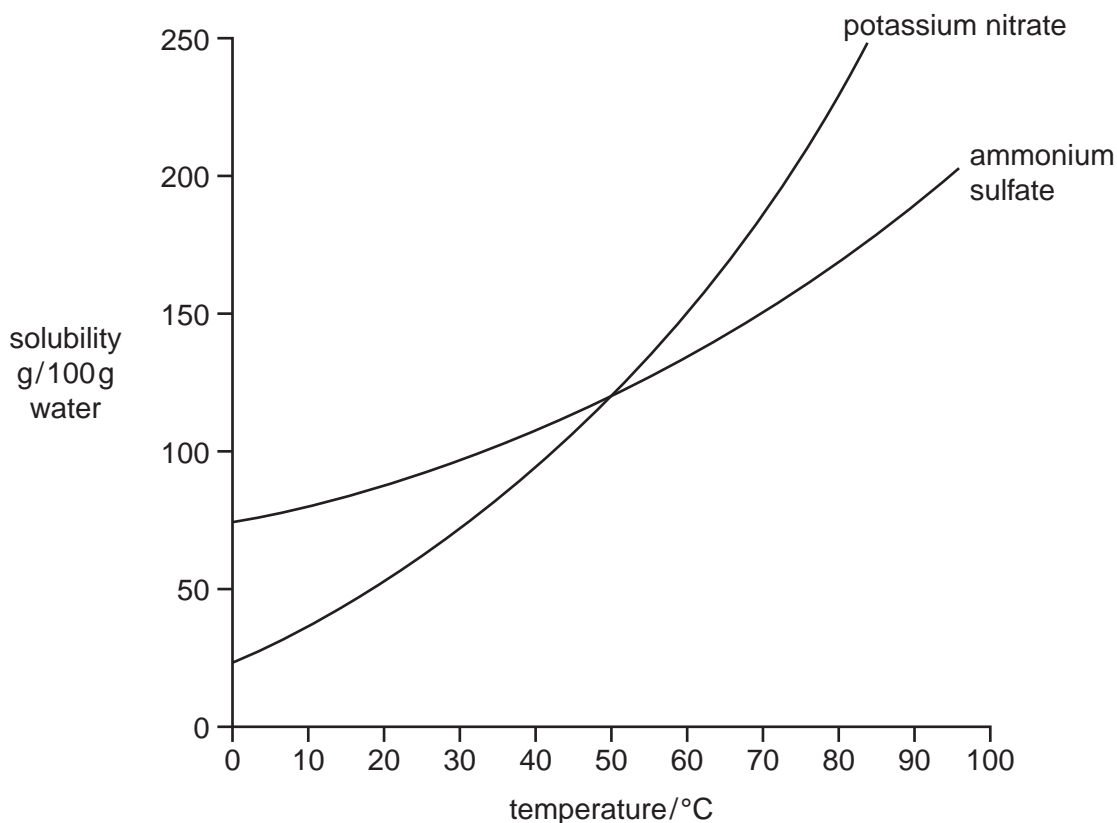

Which one of the following conclusions is correct?

- (a) Both salts are insoluble at 0 °C.
- (b) Potassium nitrate is more soluble than ammonium sulfate above 50 °C.
- (c) Potassium nitrate is more soluble than ammonium sulfate at all temperatures.
- (d) Ammonium sulfate is less soluble than potassium nitrate below 50 °C.

[1]

- 9 A student is asked to determine the percentage purity of a sample of impure magnesium carbonate.

(a) The sample is added to a previously weighed container, which is then reweighed.

$$\begin{aligned} \text{mass of container + impure magnesium carbonate} &= 8.20 \text{ g} \\ \text{mass of container} &= 6.98 \text{ g} \end{aligned}$$

Calculate the mass of impure magnesium carbonate used in the experiment.

..... g [1]

(b) The sample is placed in a volumetric flask and 50.0 cm^3 of 1.00 mol/dm^3 hydrochloric acid, an excess, is added. The stopper is placed in the top of the flask and the mixture is allowed to react.

Why should this reaction have been done in a beaker rather than in a volumetric flask?

..... [1]

(c) When the reaction has finished the solution is made up to 250 cm^3 with distilled water. This is solution **T**.

25.0 cm^3 of **T** is transferred to a conical flask and a few drops of methyl orange indicator are added.

0.100 mol/dm^3 sodium hydroxide is added to the solution from a burette until an end-point is reached.

What is the colour change of the methyl orange at the end-point?

The colour changes from to [1]

(d) The student does three titrations. The diagrams below show parts of the burette with the liquid levels at the beginning and end of each titration.

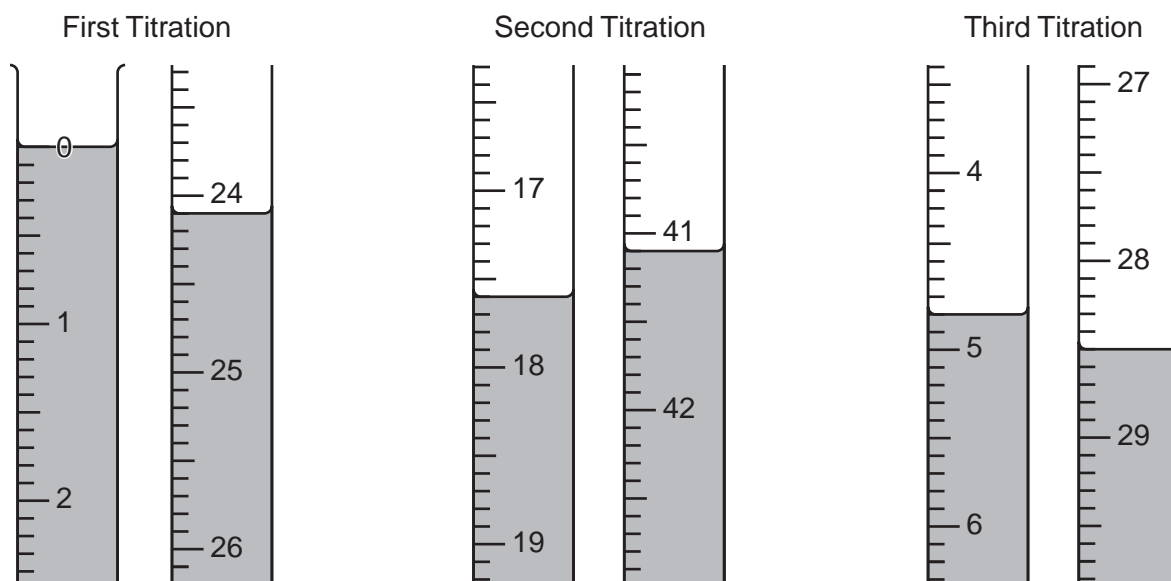

Use the diagrams to complete the following results table.

titration number	1	2	3
final burette reading/cm ³			
initial burette reading/cm ³			
volume of 0.100 mol/dm ³ sodium hydroxide/cm ³			
best titration results (✓)			

Summary

Tick (✓) the best titration results.

Using these results, the average volume of 0.100 mol/dm³ sodium hydroxide required is

..... cm³. [4]

- (e) Calculate the number of moles of sodium hydroxide in the average volume of 0.100 mol/dm³ sodium hydroxide in (d).

..... moles [1]

- (f) Using the equation and your answer to (e), deduce the number of moles of hydrochloric acid in 25.0 cm³ of T.

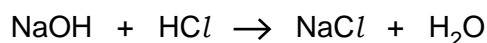

..... moles [1]

- (g) Calculate the number of moles of hydrochloric acid in 250 cm³ of T.

..... moles [1]

- (h) How many moles of hydrochloric acid are in the original 50.0 cm³ of 1.00 mol/dm³ hydrochloric acid?

..... moles [1]

- (i) By subtracting your answer in (g) from your answer in (h), calculate the number of moles of hydrochloric acid that reacts with the sample of magnesium carbonate.

..... moles [1]

- (j) Write the equation for the reaction between magnesium carbonate and hydrochloric acid.

..... [1]

- (k) Using the equation and your answer (i) deduce the number of moles of magnesium carbonate that reacts with hydrochloric acid.

..... moles [1]

- (l) (i) Calculate the relative formula mass of magnesium carbonate.
[A_r : C, 12; O, 16; Mg, 24.]

..... [1]

- (ii) Using your answers to (k) and (l)(i) calculate the mass of magnesium carbonate in the sample.

..... g [1]

- (iii) Using your answers to (a) and (l)(ii) calculate the percentage purity of the sample of magnesium carbonate.

.....% [1]

[Total: 17]

- 10 A student is given a sample of compound **S**. The table below shows the tests the student does on **S**. Complete the table by adding the conclusion for **(a)**, the observations for tests **(b)** and **(c)** and both the test and observation which lead to the conclusion for test **(d)**.

test	observations	conclusions
(a) S is dissolved in water and the resulting solution divided into three parts for test (b) , (c) and (d) .	A green solution is formed.	
(b) (i) To the first part aqueous sodium hydroxide is added until a change is seen. (ii) An excess of aqueous sodium hydroxide is added to the mixture from (i) .		S contains Cu^{2+} ions.
(c) (i) To the second part aqueous ammonia is added until a change is seen. (ii) An excess of aqueous ammonia is added to the mixture from (i) .		The presence of Cu^{2+} ions is confirmed.
(d)		S contains Cl^- ions.

Conclusion:

The formula for **S** is

[Total: 9]

- 11 A student investigates the temperature change produced when different amounts of powdered iron are added to 50 cm³ of aqueous copper(II) sulfate in a beaker as shown in the diagram below.

The initial temperature in each case is 25.0 °C.

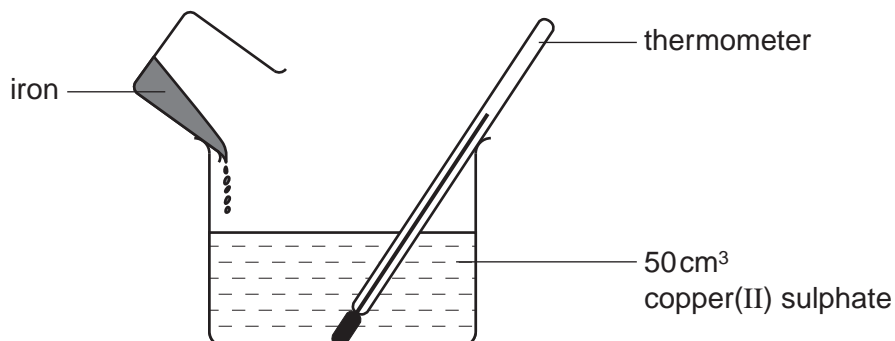

The diagrams below show parts of the thermometer stem when the thermometer records the highest temperature reached after each addition of iron.

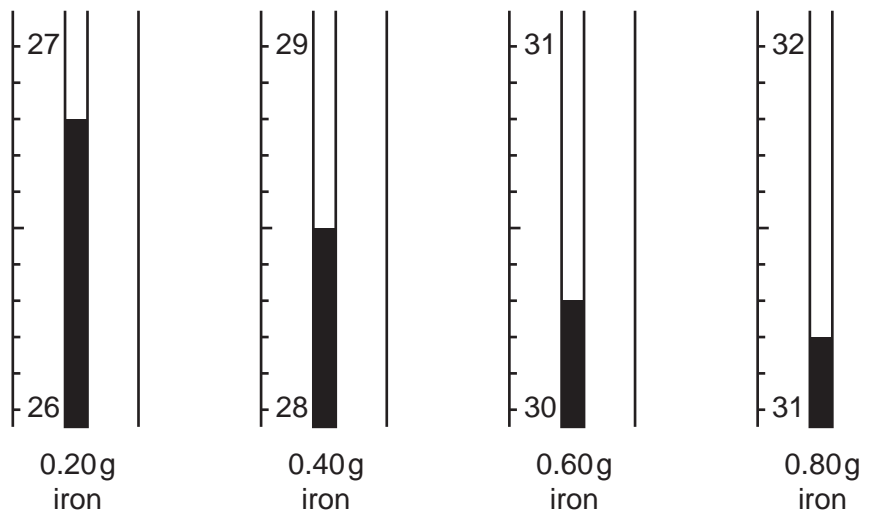

- (a) Use these diagrams to complete the table below.

volume of copper(II) sulfate/cm ³	mass of iron /g	maximum temperature /°C	temperature rise/°C
50	0.2		
50	0.4		
50	0.6		
50	0.8		
50	1.0	31.2	6.2

- (b) Plot the temperature rise against the mass of iron on the grid below and connect the points with two intersecting straight lines.

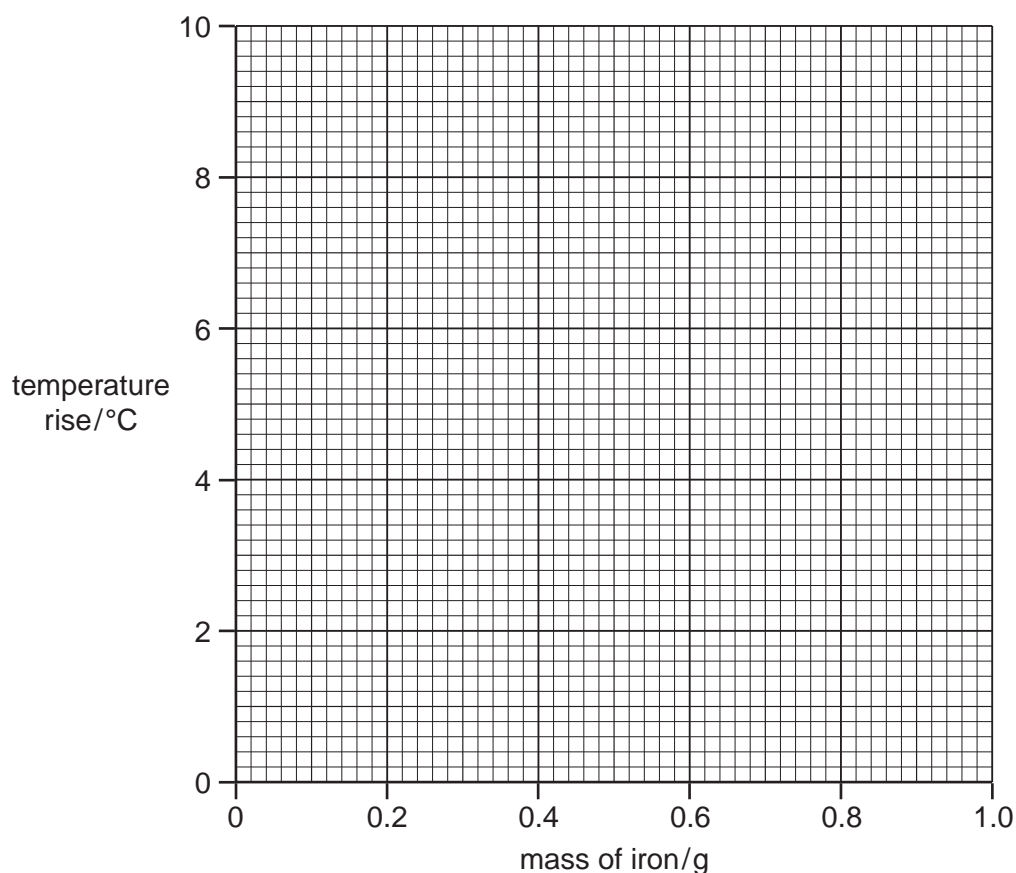

[3]

- (c) (i) Use your graphs to determine the mass of iron required to produce a temperature rise of 3.0°C.

..... g [1]

- (ii) Deduce from your graphs the mass of iron required to react completely with 50 cm³ of aqueous copper(II) sulfate.

..... g [1]

- (iii) Write the equation for the reaction between iron and copper(II) sulfate.

..... [1]

- (iv) What type of reaction is this?

- (v) Using your answer to (c)(ii) and the equation in (c)(iii), calculate the concentration of the aqueous solution of copper(II) sulfate used in the experiment.
[A_r : Fe, 56]

..... mol/dm³ [2]

- (d) State one observation, other than a rise in temperature, which can be made when iron reacts with aqueous copper(II) sulfate.

..... [1]

[Total: 12]